

LDO
AS7133H

## High Input Voltage LDO Linear Regulators AS7133H Series

### General Description

AS7133H series are low-dropout linear voltage regulators with a built-in voltage reference module, error correction module and phase compensation module. AS7133H series are based on the CMOS process and allow high voltage input with low quiescent current. This series can deliver 100mA output current and allow an input voltage as high as 40V.

### Features

Output voltage: 3.3V

High output accuracy:  $\pm 2\%$

Output Current:  $I_{OUT} = 100\text{mA}$  ( $V_{IN} = 5.5\text{V}$  and  $V_{OUT} = 3.3\text{V}$ )

Input Voltage: up to 40V

Ultra-low quiescent current:  $3\ \mu\text{A}$

Short-circuit Current: (Typ.= 20mA)

Low temperature coefficient

Ceramic capacitor can be used

Small Packages:SOT-89

### Typical Application

Ceramic capacitor can be used

SCM

Phones, cordless phones

Security Products

Water meters, power meters

### Typical Application Circuit

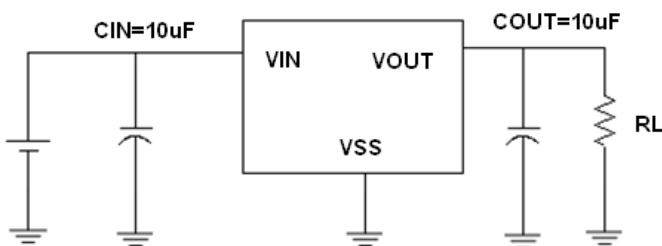

Note: The above circuit is for reference only, the value of capacitors should be adjusted to practical application.

### Pin Configuration

SOT-89-3

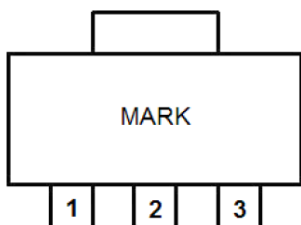

LDO
AS7133H

**High Input Voltage LDO Linear Regulators AS7133H Series**

**Pin Assignment**

Pin Number	Pin Name	Functions
1	V <sub>SS</sub>	Ground
2	V <sub>IN</sub>	Input
3	V <sub>OUT</sub>	Output

**Block Diagram**

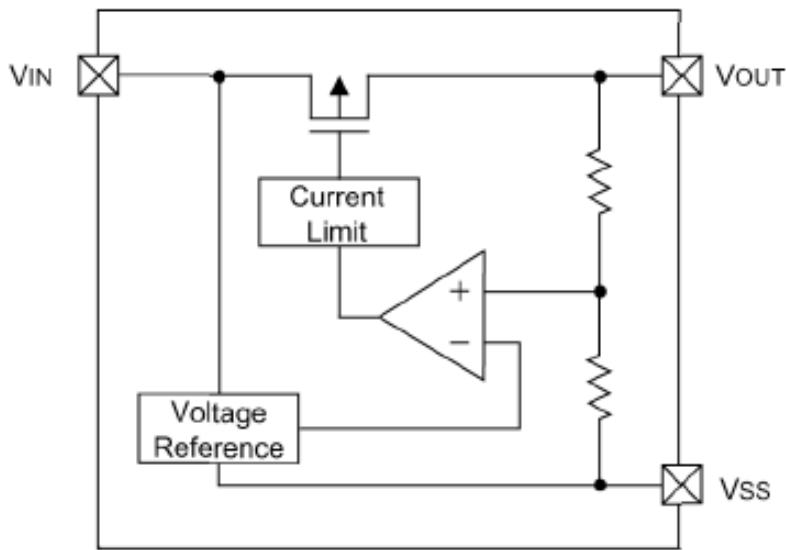

**Absolute Maximum Ratings**

Parameter	Symbol	Ratings	Units
Input Voltage	V <sub>IN</sub>	40	V
Output Voltage	V <sub>OUT</sub>	V <sub>SS</sub> -0.3~V <sub>IN</sub> +0.3	V
Output Current	I <sub>OUT</sub>	150	mA
Operating Temperature Range	T <sub>OPR</sub>	-25~+85	°C
Storage Temperature Range	T <sub>STG</sub>	-40~+150	°C
Lead Temperature		260°C, 10sec	

LDO
AS7133H

### High Input Voltage LDO Linear Regulators AS7133H Series

#### Electrical Characteristics

( $V_{IN} = V_{OUT} + 2.0V$ ,  $C_{IN} = C_L = 10\mu F$ ,  $T_a = 25^\circ C$ , unless otherwise noted)

Parameter	Symbol	Conditions	Min.	Typ.	Max.	Units
Output Voltage	$V_{OUT}$	$I_{OUT} = 10mA$	3.23	3.30	3.37	V
Input Voltage	$V_{IN}$		3.3		40	V
Maximum Output Current	$I_{OUT\_max}$	$V_{IN} = V_{OUT} + 2.2V$		100		mA
Load Regulation	$\Delta V_{OUT}$	$V_{IN} = V_{OUT} + 2.2V$ , $1mA \leq I_{OUT} \leq 100mA$		30	60	mV
Dropout Voltage	VDIF	$I_{OUT} = 10mA$		0.22		V
		$I_{OUT} = 50mA$		1.1		V
Supply Current	ISS	$V_{IN} = V_{OUT} + 2V$		3	4	$\mu A$
Line Regulations	$\frac{\Delta V_{OUT}}{\Delta V_{IN}} \times V_{OUT}$	$I_{OUT} = 1mA$ $V_{OUT} + 1V \leq V_{IN} \leq 40V$		0.04	0.1	%/V
Short-circuit Current	ISHORT	$V_{OUT} = 0V$		20	40	mA
Temperature Coefficient	$\frac{\Delta V_{OUT}}{V_{OUT} \times \Delta T_a}$	$I_{OUT} = 10mA$ $-40^\circ C \leq T_a \leq 85^\circ C$		80		ppm/ $^\circ C$

#### Packaging Information SOT-89-3

